

# GF-2

**+/-10g Tilt Compensated dual range aviation G-force meter**

**Operating Manual – English 1.00**



## Introduction

The GF-2 is a 3 1/8" G-force meter capable of measuring G-forces exerted in an aircraft up to +/-10g. The forces acting on the aircraft are easily seen on a large backlit graphic display both numerically and graphically.

The GF-2 also has the facility to record maximum G-forces obtained in permanent memory as well as a temporary memory to record G-forces reached from the time of power up. It also features 2 independent cycle counters to capture the amount of times a preset force has been exceeded.

The GF-2 is able to measure G-forces even if the instrument is not mounted exactly on the vertical axis of the aircraft.

## 1 Features

- Typical, accurate range up to 20g (from -10g to +10g)
- Records maximum measured forces in permanent memory (both positive and negative G-forces), with password protected reset facility
- Two independent cycle counters record the number of times a preset force has been exceeded
- Temporary memory for maximum positive and negative G-forces encountered (typically during a flight)
- Clear, large readable G-force numerical value (10g positive and negative)
- Scalable graphic analog display of force acting on the aircraft
- 2 axis design of the instrument allows mounting in sloped panels (i.e. panel not exactly vertical)
- Quick calibrations function for operation at temperature extremes using Earth's gravity
- Bilingual support (English or French)
- Standard 3 1/8" aircraft enclosure (can be front or rear mounted)
- Rotary control plus 2 independent buttons for easy menu navigation and user input
- Red LED illuminates every time the aircraft exceeds a preset G-force
- Large backlit graphic LCD with adjustable contrast
- Wide input supply voltage range of 8 to 30V DC with built in voltage reversal and over voltage protection for harsh electrical environments
- Light weight design
- 1 year limited warranty

## 2 GF-2 Layout

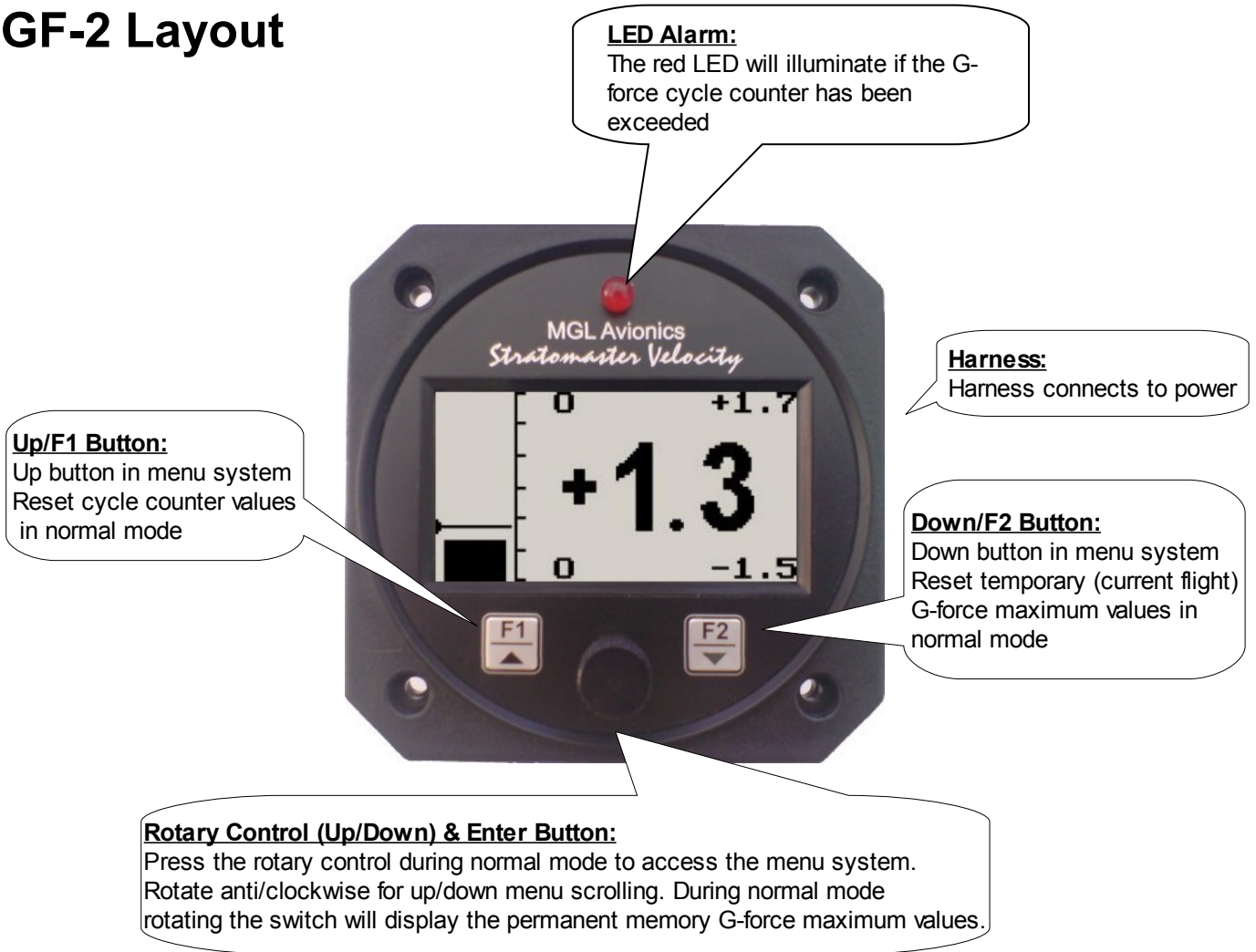

## 3 Main Display

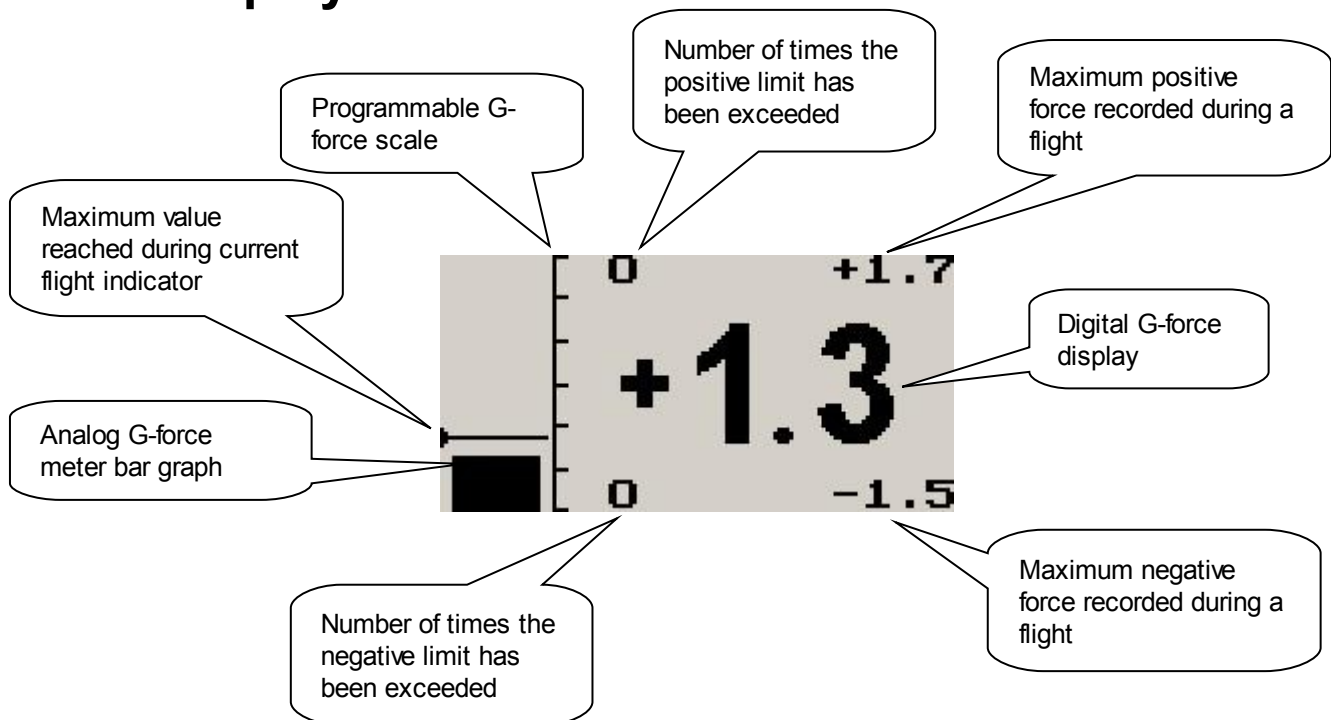

### 3.1 Reset cycle counters display

This display can be accessed by pressing the F1 key during the normal display mode. Pressing the F1 key again will reset the cycle counters. Pressing any other key will cause the GF-2 to return to the normal display mode.



**Note:** The cycle counter values are stored in non-volatile memory and are recalled on power-up.

### 3.2 Reset current flight/temporary maximum G-force values display



This display can be accessed by pressing the F2 key during the normal display mode. Pressing the F1 key will reset the temporary/current flight maximum values to the current G-force value. Pressing any other key will cause the GF-2 to return to the normal display mode.

### 3.3 Permanent maximum G-force values display

This display can be accessed by turning the rotary control either clockwise or anti-clockwise. Pressing the F1 key will reset the permanent maximum values to the current G-force value. Pressing any other key will cause the GF-2 to return to the normal display mode. If the max G-force reset code is not equal to 0000, then the code entry screen will be displayed. To avoid false recordings, the maximum G-force function is only activated 10 seconds after the instrument has powered up.



**Note:** The permanent maximum values are stored in non-volatile memory and are recalled on power-up.

# 4 Menu System

Pressing the rotary control button during the normal display mode will cause the GF-2 to enter the menu system. Use the up/down keys or the rotary control to navigate through the menu system.

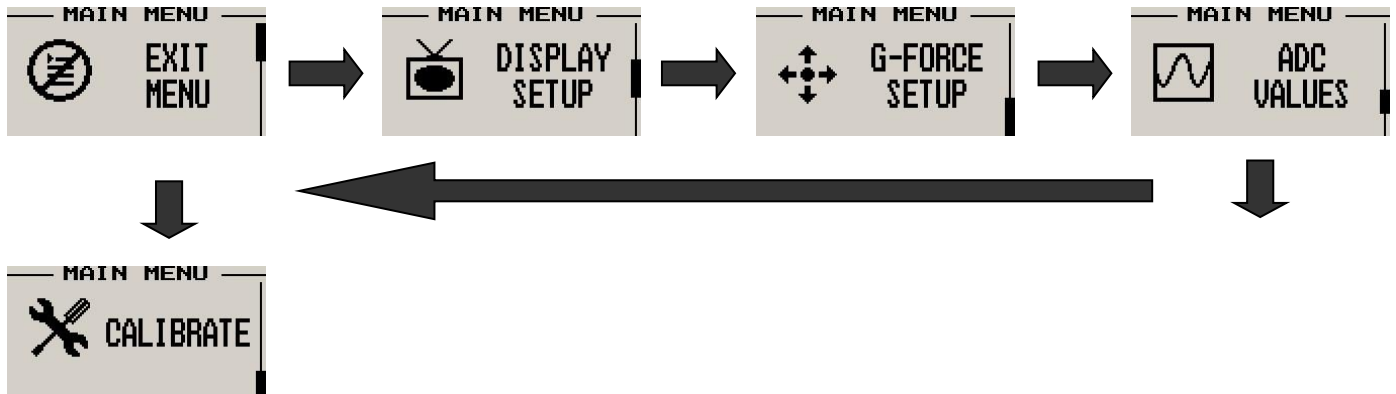

**Note:** (ADC Values and Calibrate Menus are only visible when powering up the unit and pressing the Rotary Control). The text "CALIBRATE" will appear on the intro screen when entering this mode.

**Warning:** The Calibrate Menu is for technical personnel only. Changing any values in this menu may cause the instrument to display incorrect information, and may require the instrument to be returned to the factory for recalibration.

## 4.1 Exit Menu



Pressing the rotary control on this menu item will cause the GF-2 to exit the menu system. All changes made during navigation of the menu system will be saved in non-volatile memory on exiting the menu system. If you remove power before exiting the menu the instrument will not save any changes.

## 4.2 Display Setup



Move the highlight over the "DONE" menu item and press the rotary control to return to the main menu.



Select this menu option to adjust the display contrast.

```
- DISPLAY SETUP -
*** DONE ***
ADJUST CONTRAST
BACKLIGHT: ON
LANG: ENGLISH
```

Select this menu option to turn the backlight on or off.

```
- DISPLAY SETUP -
*** DONE ***
ADJUST CONTRAST
BACKLIGHT: ON
LANG: ENGLISH
```

Select your preferred language for the GF-2. English or French.

### 4.3 G-Force Setup

```
MAIN MENU
G-FORCE
SETUP
```

The G-force menu allows the user to adjust all the G-force related parameters

```
- G-FORCE SETUP -
*** DONE ***
GF SPAN: 6g
CYCLE +: +5.0g
CYCLE -: -5.0g
Z-AXIS CAL
MAX GF RST CODE
```

Move the highlight over the "DONE" menu item and press the rotary button to return to the main menu

```
- G-FORCE SETUP -
*** DONE ***
GF SPAN: 6g
CYCLE +: +5.0g
CYCLE -: -5.0g
Z-AXIS CAL
MAX GF RST CODE
```

Set the maximum G-force value that you would like the analog bar graph to display

```
- G-FORCE SETUP -
*** DONE ***
GF SPAN: 6g
CYCLE +: +5.0g
CYCLE -: -5.0g
Z-AXIS CAL
MAX GF RST CODE
```

Set the positive G-force limit above which the cycle counter should increment  
This would typically be set to the maximum allowable G-force rating of your aircraft (positive G-force)  
The cycle count is retained if power is removed

```
- G-FORCE SETUP -
*** DONE ***
GF SPAN: 6g
CYCLE +: +5.0g
CYCLE -: -5.0g
Z-AXIS CAL
MAX GF RST CODE
```

Set the negative G-force limit above which the cycle counter should increment  
This would typically be set to the maximum allowable G-force rating of your aircraft (negative G-force)  
The cycle count is retained if power is removed

```
- G-FORCE SETUP -
*** DONE ***
GF SPAN: 6g
CYCLE +: +5.0g
CYCLE -: -5.0g
Z-AXIS CAL
MAX GF RST CODE
```

This function allows a quick calibration of the Z-axis G-force sensor. You would typically use this function to set the G-force reading to exactly 1.0g (Earth's gravity) in cases where the instrument is operated at temperature extremes (very hot or very cold). Temperature has a slight effect on the sensor and this function helps you to maintain best possible measurement accuracy should you operate at temperature extremes. In order to use this function, the instrument faceplate should be vertical to the Earth's surface within 10 degrees.

```
Z-AXIS CAL
SET 1g USING
OR G.
INSTRUMENT IN
NORMAL
ORIENTATION.
GF: +1.2
```

Use up/down keys or the rotary control to increase or decrease the reading. Approximately four key presses are required for 0.1g. Ensure that the instrument is in fact exposed to a force of 1g (Earth's gravity) in the vertical direction. Do not use this function in flight. Do not use this function if the instrument is more than 10 degrees from the vertical.

```
- G-FORCE SETUP -
*** DONE ***
GF SPAN: 6g
CYCLE +: +5.0g
CYCLE -: -5.0g
Z-AXIS CAL
MAX GF RST CODE
```

This menu option allows you to change the permanent maximum G-force values reset code. You will first be prompted to enter the current code followed by entering in a new code followed by re-entering the new code. If the new code and the re-entered code is the same, then the maximum G-force reset code is changed. **Default code is 0000.**

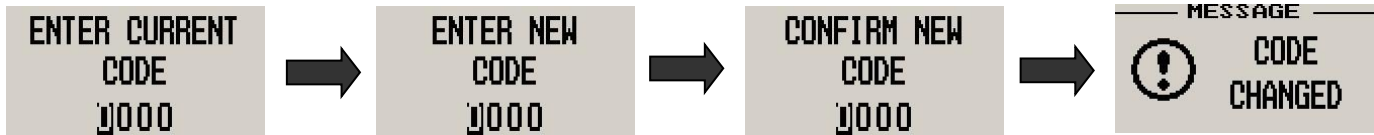

### 4.4 ADC Values



**Note:** This menu item is for technical personnel only, and is not displayed during the normal operation of the instrument. Please see section 4 above on how to access this menu item.



This menu displays the ADC values that have been read from the 2-axis G-force sensor

### 4.5 Calibrate



**Note:** This menu item is for technical personnel only, and is not displayed during the normal operation of the instrument. Please see section 4 above on how to access this menu item.



Move the highlight over the "DONE" menu item and press the rotary button to return to the main menu



#### Calibration procedure:

The above 2 menu functions allow the unit to be calibrated using the Earth's gravity as a reference. Follow the steps below when performing a calibration. The order of these steps is important:

**Step one:**

Place the instrument such that the faceplate is exactly vertical (normal operating orientation, normal side up as it would be installed in an aircraft). Select the Calibrate 1g menu option. You will see a message confirming the action.

**Step two:**

Place the instrument such that the faceplate is exactly horizontal with the display on top. If placed on a table, you would be looking down onto the display from above. Select the Calibrate 0g menu option. You will see a message confirming the action.

**Step three:**

Place the instrument in the vertical position again (same as in step one). Select the Calibrate 1g menu option again.

You have now calibrated both the horizontal and vertical G-force using Earth's gravity as the reference.

## 5 Loading Factory default settings

Pressing and holding the F1 and F2 keys simultaneously on power up will cause the GF-2 to load preprogrammed factory default settings. The following screen will be displayed:

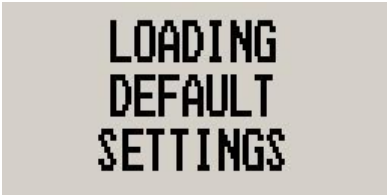

LOADING  
DEFAULT  
SETTINGS

## 6 Cleaning

The unit should not be cleaned with any abrasive substances. The screen is very sensitive to certain cleaning materials and should only be cleaned using a clean damp cloth.

**Warning:** The GF-2 is not waterproof. Serious damage could occur if the unit is exposed to water and/or spray jets.

## 7 GF-2 Specifications

<b>Operating Temperature Range</b>	-10°C to 50°C (14°F to 122°F)
<b>Storage Temperature Range</b>	-20°C to 80°C (-4°F to 176°F)
<b>Humidity</b>	<85% non-condensing
<b>Power Supply</b>	8 to 30Vdc SMPS (switch mode power supply) with built in 33V over voltage and reverse voltage protection
<b>Current Consumption</b>	Approx. 38mA @ 13.8V (backlight on) 12mA @13.8V (backlight off)
<b>Display</b>	128x64 graphic LCD display. Contrast and backlight is user configurable, green/yellow backlight
<b>ADC</b>	12bit over sampled successive approximation
<b>Dimensions</b>	see Velocity series dimensional drawing
<b>Enclosure</b>	3 1/8" ABS, black in color, front or rear mounting
<b>Weight</b>	Approx. 160 grams
<b>Non-volatile memory storage</b>	100000 write cycles
<b>G-force range</b>	+/-10g typical
<b>Maximum error over full range</b>	Less than 1% of full scale when operated at calibration temperature
<b>Temperature drift</b>	0.002g / degree C or less

## 8 Installation

The instrument must be installed exactly horizontal (when viewed from the front) so the force sensor is correctly aligned with the yaw axis of the aircraft (Z axis). The faceplate alignment should be such that it is at less than +20 degree tilt relative to the Z axis. The instrument is tolerant of sloped aircraft panels but in order to use the quick calibration function the slope relative to the Z axis should not exceed +/-10 degrees. More acute slopes can be tolerated, but performance should be checked on an individual basis.

### 8.1 Connection Diagram

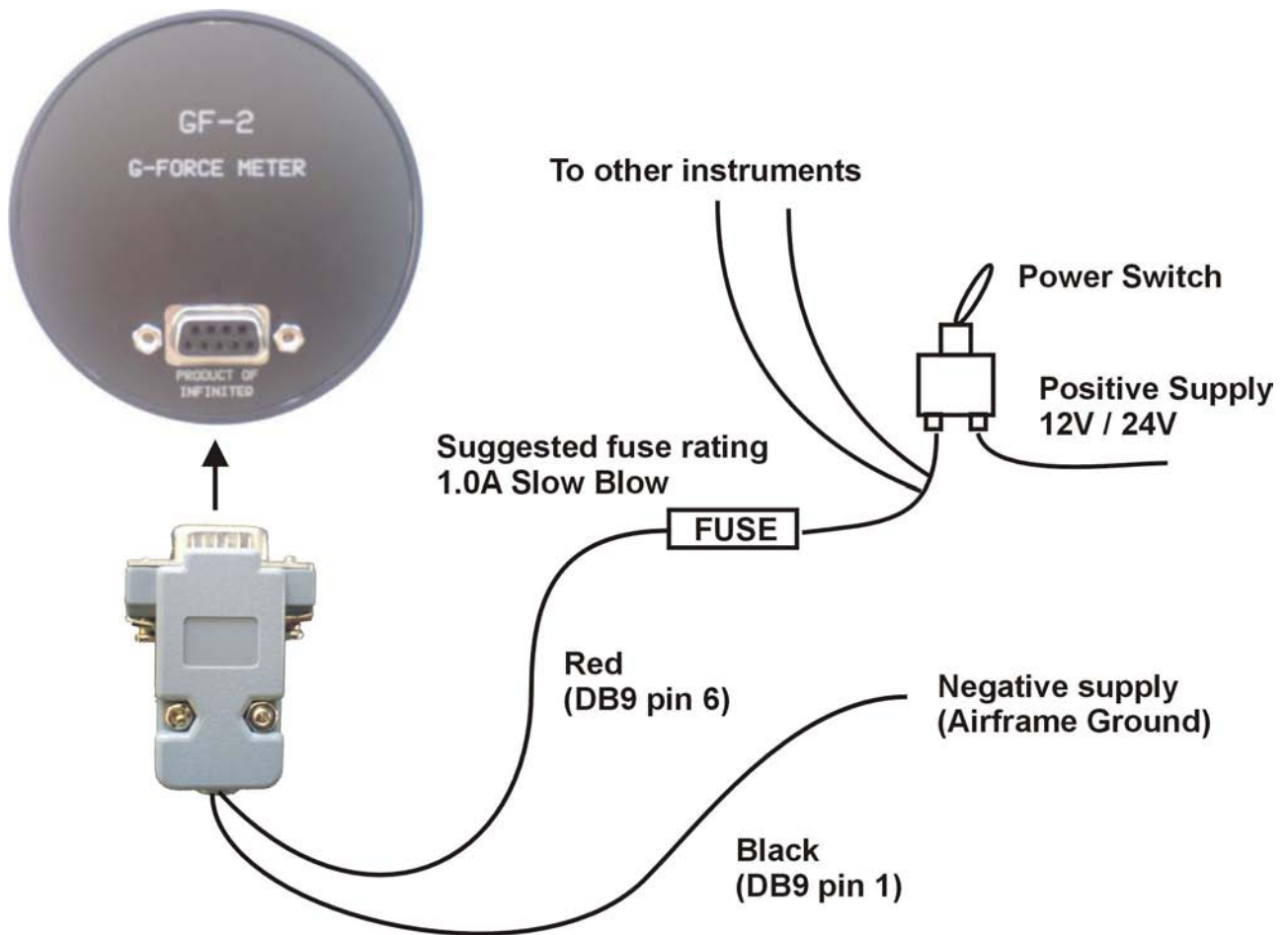

The use of an external 1A fuse is recommended. Connect the supply terminals to your aircrafts power supply. The GF-2 can be used on both 12V and 24V without the use of any pre-regulators. Ensure that the supply voltage will not drop below 8V during operation as this may result in incorrect G-force readings.

### 8.2 GF-2 DB9 Cable connections

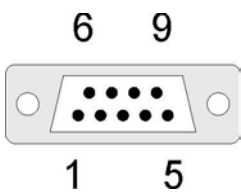

DB 9 Pin	Color	Function
1	Black	Ground
4	NC	Airtalk communication (Not connected) Used for firmware upgrading
6	Red	8-30Vdc power



## 9 Warranty

This product carries a warranty for a period of one year from date of purchase against faulty workmanship or defective materials, provided there is no evidence that the unit has been mishandled or misused. Warranty is limited to the replacement of faulty components and includes the cost of labour. Shipping costs are for the account of the purchaser.

**Note:** Product warranty excludes damages caused by unprotected, unsuitable or incorrectly wired electrical supplies and/or sensors, and damage caused by inductive loads.

## 10 Disclaimer

Operation of this instrument is the sole responsibility of the purchaser of the unit. The user must make themselves familiar with the operation of this instrument and the effect of any possible failure or malfunction.

This instrument is not certified by the FAA. Fitting of this instrument to certified aircraft is subject to the rules and conditions pertaining to such in your country. Please check with your local aviation authorities if in doubt. This instrument is intended for ultralight, microlight, homebuilt and experimental aircraft. Operation of this instrument is the sole responsibility of the pilot in command (PIC) of the aircraft. This person must be proficient and carry a valid and relevant pilot's license. This person has to make themselves familiar with the operation of this instrument and the effect of any possible failure or malfunction. Under no circumstances does the manufacturer condone usage of this instrument for IFR flights.

The manufacturer reserves the right to alter any specification without prior notice.

## Other instruments in the *Stratomaster Velocity* series

<b>ALT-3</b>	Encoding aviation altimeter and Vertical speed indicator (VSI)
<b>ALT-4</b>	Encoding aviation altimeter with Serial RS232 & Parallel Gillham code output
<b>ASI-3</b>	Airspeed indicator (ASI) with automatic flight log
<b>ASX-2</b>	Encoding aviation altimeter and Airspeed indicator (ASI)
<b>AV-2</b>	Artificial horizon and magnetic compass indicator
<b>E-1</b>	Universal engine monitor
<b>FLIGHT-2</b>	Primary Flight instrument
<b>FF-3</b>	Fuel Computer (single or dual fuel tanks)
<b>GF-2</b>	+10G tilt compensated dual range G-force meter
<b>MAP-2</b>	Manifold pressure and RPM Indicator
<b>ROTOR-1</b>	Dual Rotor / Engine tachometer
<b>RTC-1</b>	Aviation real time clock (RTC), outside air temperature (OAT) and Voltage display
<b>RV-3</b>	Universal engine / Rotor RPM Indicator
<b>TC-2</b>	4-Channel thermocouple (EGT/CHT) indicator
<b>TC-3</b>	12-Channel thermocouple (EGT/CHT) indicator
<b>TP-2</b>	Universal temperature and pressure gauge